

TITLE 6 (Animal Control Code)

Adapted for the City of Shelby, Montana

from

Model Animal Control Ordinances authored by:

**National Animal Interest Alliance (NAIA),
American Veterinary Medical Association (AVMA),**

and other resources available in the public domain:

**Title 6 Animals, Shelby Municipal Code,
Repealed Shelby City Ordinance 785,
2007 Montana Code Annotated (MCA),
National Association of State Public Health Veterinarians (NASPHV),
Centers for Disease Control (CDC),
Humane Society of the United States,
National Animal Control Association (NACA),
PetSmart Charities,
Petfinder.com & Petfinder.com Foundation,
Journal of Applied Animal Welfare Science (JAAWS),
American Association of Feline Practitioners (AAFP),
Metro Animal Resource Services, Inc.,
Brevard County Animal Services (Florida),
San Antonio Animal Care Services (Texas),
Health Code of the City of New York (Animals),
Kent County Maryland Animal Control Regulation,
City of Dubuque Health Services Department (Iowa),
Animal Legal and Historical Center, MI St. Univ., College of Law,
United States Department of Agriculture (USDA/APHIS),
Born Free USA and the Animal Protection Institute (API),
American Zoological and Aquarium Association (AZA),
American Society for the Prevention of Cruelty to Animals (ASPCA),
Captive Wild Animal Protection Coalition (CWAPC),
City of Vancouver, B.C. Animal Control By-Law.**

**TITLE 6
(Animal Control Code)**

Mission Statement.

The purpose of this Animal Control Code is to provide for the public health and safety of both the citizens and animals in our community.

Sections:

- 01. Definitions.**
- 02. Owner Responsibility.**
- 03. Rabies Prevention and Control; Other Communicable Diseases.**
- 04. Registration and Licensing.**
- 05. Nuisance Animals.**
- 06. At-risk Animals.**
- 07. Dangerous Animals.**
- 08. Wild Animals and Exotic Animals.**
- 09. Feral Cat Plan.**
- 10. Cruelty, Abuse, Abandonment, and Neglect.**
- 11. Confinement.**
- 12. Animal Facilities.**
- 13. Complaint Procedure.**
- 14. Fees and Fines.**
- 15. Animal Control Officer.**
- 16. General Provisions and Administration.**

Appendices:

- A. Animal Control Complaint Form.**
- B. (reserved)**
- C. (reserved)**
- D. (reserved)**
- Y. 2007 MCA (Montana Code Annotated) References.**
- Z. Running At-large Decision Chart.**

01. Definitions.

Unless the context requires otherwise, the following definitions apply throughout this Animal Control Code:

Abandonment – The willful and intentional leaving behind or desertion of an animal causing such animal to become a public charge.

Abuse – A deliberate act of inflicting physical pain, suffering, or death on an animal, or an act that continually causes an animal to be overloaded or forced to work in a manner unsuitable to its species, breed, condition, or health.

Adequate care – Care consistent with the normal requirements and feeding habits of the animal's size, species, and breed, this term encompasses all aspects of the overall care of an animal to include, but not necessarily limited to, a sanitary and safe shelter that provides protection from the weather, sufficient ventilation, appropriate heating or cooling for the temperature, wholesome and adequate food and clean water, fresh air, space, light, exercise, current communicable disease vaccination, and appropriate veterinary care.

Animal—For the purposes of this code, animal shall mean any living thing scientifically classified under the “Kingdom” of Animals, exclusive of human beings, irrespective of whether or not the animal is generally considered domesticated or wild.

Animal Control Officer – The person or persons designated by the local government to enforce this code.

Animal Control Advisory Board – A group of community volunteers appointed by the Mayor of the City, and as described under General Provisions and Administration.

Animal facility – Any activity or endeavor that results in the production of income, or other valuable consideration, from live animals shall be construed to constitute an Animal Facility, whether or not the activity is identified to the City as a for-profit or non-profit business activity, and includes but is not limited to such enterprises as a pet shop, grooming activity, kennel, cattery, training activity, stable, auction, breeding activity, boarding activity, shelter, research facility, animal dealer, performing animal exhibition, and the like, but excluding any activity regulated by State or federal agencies and veterinary medical facilities.

Animal shelter – A public or private facility designated or recognized by the City for the purpose of impounding and caring for animals.

At-large – An animal off the premises of the owner or keeper and NOT under restraint and control.

At-large return service – The act of taking an animal found at-large back to its home for a reasonable fee rather than impounding the animal in the City's animal shelter.

4/30/2008

Attack – an assault, without provocation or justification, making actual physical contact between a human being or another animal resulting in serious physical damage and harm to the victim.

Caregiver – A person who feeds and waters feral cats, and watches over a colony for sick or injured cats in cooperation with the Animal Control Officer.

Cattery – An establishment maintained for the purpose of breeding and selling domestic cats.

Colony – A group of four or more feral cats living together in a group.

Collar – A leather, plastic, fabric, or metal band placed around the neck of an animal to identify it or restrain such animal by attachment to a leash or tether.

Confinement – To restrict within a boundary or the limits of a bounded region.

Control – To exercise authority over; direct; command. An animal shall be considered under control if it is under restraint and obedient to a competent and legally responsible person's commands. An animal roaming free and out of the sight, hearing, or supervision of its owner or other responsible person, or unresponsive to the commands of such person constitutes an animal NOT under control.

Cruelty – An overt act committed with the intent to harm or needlessly kill an animal or committed out of depraved indifference for the animal's wellbeing, including but not limited to torture, maiming, beating, or otherwise committing or allowing violence that causes injury or death, or contributes to unconscionable suffering.

Domestic – A tame animal species generally accustomed to living with or near people as a pet or farm animal and widely accepted by the general public as suitable for human contact and interaction thus posing little threat of harm to the general public when properly cared for by their owners.

Ear tipping or Ear cropping – A cost effective removal, under professional anesthesia, of the uppermost tip of the feline ear for identification purposes, reflecting that a feral cat has been previously trapped, neutered, vaccinated, and returned (T-N-R) to the vicinity of its home colony.

Enclosure – A fence or structure suitable to prevent escape of the animal or any access to the animal, especially by children from outside the structure or entry of children into the structure.

Exotic – A non-domesticated species introduced to the region from another distant region or unfamiliar culture.

Expose or Exposure – The actual introduction of saliva or neural (brain or spinal column) tissue of a rabid animal into: 1) an open wound such as a bite or scratch on the skin, or 2) the mucous membranes such as the nose, mouth, eyes of a non-infected mammal. Merely being in the presence of a rabid animal does NOT rise to the level of exposure to rabies. An actual exchange of the aforementioned bodily fluids or tissue is necessary to constitute exposure, thus posing a threat to the victim of contracting the rabies virus and requiring immediate cleansing and flushing of the contact site with soap, water, iodine and submitting the victim to medical or veterinary care as soon as practical for post exposure prophylaxis. This is an urgent situation, but does NOT constitute an emergency.

Feral – A normally domestic animal species existing in a wild state, as the result of surviving for a substantial period of time without the care of an owner usually due to abandonment, or the offspring of a stray animal experiencing little or no human contact or socialization in the formative months. A feral cat is a very poor candidate for adoption because humans are instinctively perceived as dangerous and untrustworthy from the animal's perspective.

Household – A property where animals are kept as part of an occupied residence and includes other buildings such as kennels, barns, sheds, and other structures and pens, corrals, or other enclosures on one contiguous piece of property.

Humane – Compassionate, kind and gentle, with an emphasis on showing respect to the subject.

Kennel – A facility serving as temporary or permanent housing for dogs, cats, and other domestic animals maintained for the purpose of breeding, selling, training, boarding, or sheltering such animals. Depending on applicable City zoning regulations, a kennel may be maintained as part of a household or may occupy a different property and may be operated as a hobby or a business.

Licensing authority – The agency or department of the City or any designated representative thereof charged with administering the issuance and/or revocation of registrations, licenses, and permits under the provisions of this code.

Mammal – Any animal of a class (Mammalia) of warm-blooded higher vertebrates that nourish their young with milk secreted from mammary glands and have skin covered more or less with hair, including human beings.

Muzzle – A commercially obtained device specifically produced and intended for use to prevent an animal from biting, and which is properly fitted so as NOT to hinder or interfere with an animals breathing, panting, or vision, and adequately constructed to accomplish said objectives without failure.

NASPHV Form 51 – Rabies Vaccination Certificate, which can be obtained from vaccine manufacturers, the National Association of State Public Health Veterinarians, Centers for

4/30/2008

Disease Control, or via an internet connected computer using a PDF fill in form at:
<http://www.cdc.gov/rabies/publications/>

Neglect – An act involving owner failure to provide for an animal’s health or safety including, but not limited to adequate care, properly confining an animal in a manner appropriate to its species, breed, age, condition, and if applicable designation as either an at-risk or dangerous animal.

Neutered, or neutering, or neuter – Rendered permanently incapable of reproduction, regardless of gender, and includes the term “spay”.

Owner – A person having the right of property of an animal.

Person – Any individual, corporation, partnership, organization, or institution commonly recognized by law as a unit.

Pet shop – An establishment engaged in the business of buying or selling animals at retail for profit.

Rabies Vaccination – The inoculation of an animal against rabies in accordance with State law and the “Compendium of Animal Rabies Prevention and Control” published annually in January by the National Association of State Public Health Veterinarians.

“Running at-large or runs at-large or run at-large” – The willful act of allowing an animal to run loose in the sense of strolling at-large without control; as wandering, roving, rambling at will.

Restraint – The use of strong force and exercising the authority necessary to influence behavior in order to prevent or suppress some action; to curb, check, or inhibit. An animal shall be considered under restraint if it is responsive to the exercise of authority necessary to influence its behavior in order to prevent or stop harmful actions to people, other animals, or property, and is: a) securely confined within the real property limits of its owner or other persons consenting thereto, or b) secured by a leash or lead, or c) “at heel” beside a competent person, or d) within the personal presence and attention of any person as will reasonably control the conduct of said animal, or e) confined within a vehicle in a manner that prevents escape, or access by children, or accidental injury to the animal.

Secure Enclosure – A transportation or outdoor structure constructed of sufficient height and materials to securely contain the animal and prevent any access to the animal, to include but not limited to, continuous use of a keyed or combination lock, and constructed with a top and bottom that will absolutely prevent the animal’s escape by climbing over or digging under the sides of said enclosure. The overall size of the enclosure must be adequate for the animal confined therein to prevent injury or distress.

Stable – A facility maintained for the purpose of keeping, boarding, training, or selling horses, donkeys, mules, and other domestic farm animals.

4/30/2008

Stray – A companion pet animal that previously lived in human homes but due to a variety of reasons like abandonment, eviction, getting lost, running away, or accidental escape. These homeless animals struggle to survive, and are usually good candidates for adoption and human socialization.

Tether – Any rope, chain, or cable attached to an animal's collar or harness at one end and a swivel devise securely imbedded in the ground at the other end, in order to restrict an animal's mobility to a specific perimeter which automatically remains constant in approximate area. A tether may NOT be of a weight that causes muscle strain or physical discomfort to the animal.

Vaccination – The inoculation of an animal against a communicable disease which jeopardizes the health or safety of the people or registered animals within the City.

Wild – Any non-domestic animal.

DRAFT

02. Owner Responsibility.

This Animal Control Code is designed to: a) ensure the safety and well being of both the animals and people residing in our City, b) create an alliance and sense of commonality between our City officials and responsible animal owners, and c) swiftly and effectively identify and deal with problematic animals and their owners. To be recognized as a responsible animal owner in this City, you will voluntarily choose to do the following:

A. Anticipate the behavior of your animal. There is no one who knows your animal better than you. According to State law, you are liable the first time your animal bites. It is your animal that will pay the ultimate price, most likely with its life, and you have the potential to lose everything you own now or in the future.

B. Provide adequate care to your animal. Please reference the definition of adequate care and what that entails. Animals are totally dependent on you and your ability and inclination to provide them with the minimum components necessary to sustain their lives and keep them healthy and thriving. Your failure to provide for your animal can lead to criminal charges for cruelty under State law.

C. Vaccinate for rabies, neuter, and register your animal. Aside from providing your animal with all the components of adequate care, these three actions will do more to keep you and your animal safe and out of serious trouble in this City than anything else you do.

D. Restrain and confine your animal. Again, this refers to your own knowledge of your animal and your exercise of authority over your animal's behavior by anticipating how your animal may react in any given situation. You must be in control of your animal at all times, and so you may need to leash your animal for you to be in control. Additionally, soft muzzles can be helpful in circumstances where you are unsure if your animal may bite. If your fence needs to be fixed, repair it. To keep your animals safe you need to curb threatening or aggressive behavior because some people are so afraid of animals that they may perceive your animal to be imminently dangerous. The ultimate result could be the death of your pet.

E. Prevent your animal from becoming a nuisance. Keeping your animal confined on your own property and under your unquestionable control when off your property, promptly picking up your animal's waste, bringing your animal indoors at night so it doesn't disturb the neighborhood's sleep while also protecting it from nocturnal predators, inhibiting your animal's ability to damage another's property, and preventing your animal from chasing or intimidating anything or anybody will virtually eliminate any reason for anyone to ever file a complaint against your animal.

Our City is pet friendly. The Animal Control Officer is your animal's best friend and guardian, not someone to be outsmarted or feared. If your animal gets away from you, contact the Animal Control Officer to assist you. Our City is committed to making our community a model of reasonable animal control that elevates public acceptance and compliance far above the norm.

03. Rabies Prevention and Control; Other Communicable Diseases.

A. Rabies is almost always fatal, especially after symptoms present. All mammals, including human beings, can contract rabies. The rabies virus is transmitted by the introduction of infected saliva and neural tissue into a wound or mucous membrane. Canine to canine rabies transmission has been eliminated in the United States. Rabies is rare in vaccinated animals; therefore:

1. it is unlawful to own, keep, house, shelter, or harbor a non-human mammal over four months of age within the City that is NOT currently vaccinated against rabies, as evidenced by NASPHV Form 51;
2. rabies vaccinations shall be administered by a licensed veterinarian in accordance with State law and the current Compendium of Animal Rabies Prevention and Control, authored by the National Association of State Public Health Veterinarians (NASPHV);
3. it is unlawful to transport, own, keep, house, shelter, or harbor a dog in this City that is imported from a country or area where canine to canine transmission of rabies exists.

B. Proof of rabies vaccination from a State licensed veterinarian shall be kept on the premises of the animal owner and also on the premises where the animal is located.

C. Rabies vaccines vary in duration of effectiveness; currently from one to four years. The frequency of City animal registration shall be tied directly to the duration of efficacy of the rabies vaccine given to a specific animal.

D. A mammal is considered currently vaccinated and is considered immunized if the initial vaccine was administered at least 28 days previously or booster vaccinations have been administered per the NASPHV Compendium of Rabies Control and Prevention.

E. All vaccinated non-human mammals shall be identified by a current rabies tag worn on a collar or other means such as microchip, tattoo, or ear-tipping that may be acceptable as agreed to in writing by the Animal Control Officer to ensure the safety of the animal when off the premises of the owner. Failure to protect the animal by clearly identifying its rabies vaccination could result in accidental euthanasia and other penalties for neglect.

F. An unvaccinated non-human mammal that appears sick with signs of rabies and bites another mammal, or an unvaccinated non-human mammal that is bitten by a rabid animal, or any non-human mammal that appears sick with signs of rabies regardless of its vaccination status shall be immediately:

1. euthanized in as professional and humane a manner as possible given the circumstances, by a licensed veterinarian, an Animal Control Officer, or police officer all of whom shall exercise great care to preserve and keep intact the head and spinal column for testing;
2. reported to the public health office;
3. preserved for testing, especially the head of the animal or the entire body of a bat or other small animal, and kept cold but NOT frozen;

4. handled only under the direction of the public health officer or veterinarian.

G. A currently vaccinated non-human mammal that is bitten by a rabid animal shall be immediately:

1. revaccinated;
2. released to the owner's control;
3. confined on the owner's premises for 45 days observation, and released from observation only upon veterinarian's certification of health.

H. A currently vaccinated non-human mammal that bites another animal shall be:

1. impounded, upon prepayment of impound fees, fines, and other applicable charges with a veterinarian of the City's choosing or at the City animal shelter for a minimum of 10 days observation; or relinquishment of ownership of the animal to the City for disposition;
2. euthanized at the first signs of rabies infection, preserved for testing, and handled only under the direction of the public health officer or veterinarian.
3. automatically designated as a dangerous animal and subjected to sanctions identified under the section heading "Dangerous Animals" of this code.

I. An unvaccinated non-human mammal that bites another mammal, but does NOT show signs of illness, shall be:

1. impounded, upon prepayment of impound fees, fines, and other applicable charges with a veterinarian of the City's choosing or at the City animal shelter for 120 days observation; or relinquishment of ownership of the animal to the City for disposition;
2. reported to the public health office;
3. euthanized at the first signs of rabies infection, preserved for testing, and handled only under the direction of the public health officer or veterinarian;
4. vaccinated initially at 30 days prior to release from impound to avoid confusion between reaction to vaccination versus rabies symptoms;
5. automatically designated as a dangerous animal and subjected to both the mandatory and optional sanctions identified under the section heading "Dangerous Animals" of this code.

J. Animals which shall be automatically confirmed as rabid when considering actions to be taken after another mammal's exposure to them are bats and wild carnivorous mammals that are NOT suitable or available for testing.

K. The risk of rabies transmission is highest among wild animals; especially bats, skunks, raccoons, coyotes, foxes, and these animals should be avoided by humans and their pet animals and removed from the City's jurisdictional boundaries by whatever means possible.

L. Any person having knowledge of an animal bite within the City's jurisdiction, to include a veterinarian or medical doctor, is required to immediately inform the Animal Control Officer, so that an investigation can be initiated. A veterinarian or medical doctor shall be held harmless as a result of informing the Animal Control Officer of an animal bite, and is

4/30/2008

authorized to supply copies of documentation and records as requested in furtherance of the public interest.

M. The owner of an animal that bites another animal is liable for and shall pay all the expenses incurred by the victim of such animal.

N. Other communicable diseases which may constitute a public health emergency, such as Avian Flu, Mad Cow Disease, Salmonella, Herpes B, and the like shall be addressed outside the purview of this Animal Control Code, given that the City and State are authorized to take any appropriate action to protect the health and well-being of the citizens of this community.

O. Depending on the particular circumstances, an animal that has a communicable disease endangering other animals or humans shall be impounded at either a Veterinary Medical Facility or the City animal shelter for treatment or other appropriate disposition, including euthanasia.

DRAFT

04. Registration and Licensing.

A. Animal registration is a service afforded the citizens of the City, with substantial monetary and safety privileges extended to the animals residing in the City and their owners:

1. minimal fines for infrequent nuisance behavior;
2. return of an at-large animal to its home rather than impound in the City shelter, except when the animal is under or imminently subject to an at-risk or dangerous animal designation, or is NOT neutered;
3. at-cost identification tag containing adequate owner information to allow return of the animal to its home;
4. access to low cost clinics that may be provided or coordinated by the City, such as immunization, spay-neuter, or microchip implant;
5. fire department rescue alerts of animals potentially in a burning structure;
6. permanent City identification number with record update capability;
7. presumption of innocence bias in favor of a registered animal when a conflict occurs with an unregistered animal.
8. reduced likelihood of euthanasia or ear-tipping in trapping schemes when the animal is also micro chipped (see Feral Cat Plan);
9. at home quarantine when bitten by another mammal;
10. reminder notices for rabies booster shots by email or USPS;
11. access to all outdoor public facilities, including but not limited to parks, campgrounds, dog socialization parks, walking trails, bike paths, sidewalks, roads, rights-of-way, parades, fairgrounds, lakes, reservoirs, rivers;
12. restraint and control privileges as long as the animal is NOT designated as at-risk or dangerous or imminently subject to said designations;

B. Animal registration record formats shall be computerized, with an offsite backup, and include all data on NASPHV Form 51, and other desirable information such as permanent as well as temporary addresses, City control number of registration, special animal certifications, original registration date, last update date, mammal or non-mammal, carnivorous or non-carnivorous by scientific classification, species, breed, digital picture of animal, at-risk or dangerous animal designation and associated dates, (microchip information such as: a) chip manufacturer b) chip implant ID number c) frequency of chip 125kHz or 134.2kHz, d) retrieval database name and phone number), other identifying marks such as a SSAN tattooed on inner thigh of animal, and any other information deemed necessary or helpful in the City's ability to reunite an animal with its owner as the result of a major catastrophe. Asterisked items below shall be accompanied by a statement that says "The following information is voluntarily provided, and shall be used solely for the purposes of reuniting an animal with its owner": cell phone numbers*, email addresses*, nearest relative* or other point of contact* not living in the City and their phone number* and address*.

C. Animal City registration for all mammals shall be tied directly to proof and expiration of current and licensed rabies vaccination by the submission of NASPHV Form 51 or a similar form that includes all information on that form. The City registration shall be set for

renewal at the expiration of the rabies vaccination, so that if a rabies vaccine is for three years, the City registration shall also be for three years, and shall be renewed by the owner prior to expiration. The City shall ensure that reminder notifications are mailed by regular mail to the owner's address at least thirty days prior to expiration of the registration.

D. Animal City registration shall be for a lifetime when the animal is NOT a mammal, is NOT subject to other communicable disease inoculations or boosters required by the City, and otherwise permitted within the City's jurisdiction. All other registrations shall expire annually.

E. The City may waive registration fees for animals in service to other publicly funded agencies, such as police dogs, but such animal must still be registered and in compliance with rabies vaccination requirements.

F. Registration fees shall be set aside in a fund specifically for the City's animal control programs including administration, officer training, public education, low cost clinics, and the like.

G. Registration fees shall be subject to a 25 percent discount for proof of neutering, as certified by a local veterinarian.

H. Registration fees shall be subject to an additional 15 percent discount for current proof of ALL inoculations involving other communicable diseases applicable to the particular species of animal, as specified by a local veterinarian of the City's choosing.

I. Registration fees shall be discounted by an additional 10 percent for an animal that is also micro chipped as scanner-verified by a local veterinarian or Animal Control Officer. Documentation including the microchip manufacturer, i.e. HomeAgain/AVID/etc., owner locator database/service name and its phone number, and any other microchip information available should be provided by the animal owner for City registration data. Microchip implants help identify animal owners, but the technology lacks standardization of chip frequency, universal scanners, centralization of data, and free public access to those databases.

J. Baby animals shall be registered initially between three and four months of age for rabies vaccination, and subsequent registration record updates shall be required at six months of age for proof of neutering, and again at one year of age for rabies vaccine booster as applicable to the species. This series of registration updates shall be assessed as one registration fee unless the animal owner fails to make updates to the registration in a timely manner. Registration records may be transferred to a new owner in the case of adopted baby animals.

K. Temporary residents of the City may register an animal accompanying them in order to avail themselves and their animal of the privileges associated with registration.

4/30/2008

L. City officials charged with the oversight and enforcement of this Animal Control Code shall take extraordinary measures to ensure the safety and preservation of the City's registered animals, and only in the most dire of emergencies to the public health shall City registered animals be subjected to mass confiscation or mass destruction, and only then by court order.

M. An animal owner shall notify the City upon the death of an animal to avoid unnecessarily alerting the fire department of an animal in jeopardy.

DRAFT

05. Nuisance Animals.

A. An animal becomes a nuisance animal when it:

1. runs at-large, is registered with the City (implies current rabies vaccination if the animal is a MAMMAL), is neutered, and is NOT designated as an at-risk or dangerous animal or imminently subject to such designation;
2. is permitted to damage, soil, defile, or defecate on private property other than property possessed or controlled by the animal owner or on public property such as walks, rights-of-way, and recreation areas unless such waste/excrement/feces is immediately removed in a plastic bag knotted to seal in the contents and odors, and properly disposed of by the animal owner or handler in a City dumpster;
3. is permitted to disturb the peace of the surrounding neighborhood by making excessive noise, including but not limited to howling, barking, and yelping in a habitual, consistent, or persistent manner;
4. is permitted to chase vehicles;
5. is permitted to interfere with persons or other domestic animals on public property;
6. runs at-large and is a small, non-carnivorous mammal without a current licensed rabies vaccination because said animals have virtually no history of rabies transmission and includes lagomorphs (rabbits and hares) and other small rodents such as: hamsters, guinea pigs, gerbils, chipmunks, etc. A public health official, a veterinarian, and a medical doctor should all be consulted in the event of a human bite by a small rodent. Pest animals such as rats and mice are mammals and omnivores (sometimes meat-eating) and are therefore specifically excluded from this group.

B. The City shall provide "at-large return service" as a cost effective measure for the City, as well as a benefit to responsible animal owners. The purpose of this service is to provide a win-win solution to an otherwise frustrating and costly problem. In order to accomplish this service, the Animal Control Officer must be able to place the animal directly in the owner's custody or properly confine it on the owner's property after ensuring the animal is currently registered, vaccinated, neutered, and NOT designated as an at-risk or dangerous animal or imminently subject to such designation.

C. At-large return service shall be provided by the Animal Control Officer as follows:

1. A nuisance animal found at-large within one block of the animal's residence shall be returned to the owner, in lieu of impound, free of charge.
2. A nuisance animal found at-large farther than one block of the animal's residence shall be returned to the owner or owner's property, in lieu of impound, for a minimal fee NOT to exceed \$5 dollars less than the daily impound fee if paid to the City within 3 workdays. The maximum fee shall include an additional \$5 administrative fee plus a \$1 per day penalty if not paid within 3 workdays or the City must send a bill, such as a line item charge on the water/garbage bill or separately.
3. In the event that a currently vaccinated and registered at-large animal cannot be returned directly to the owner or alternatively to the owner's property because it cannot be confined properly, the Animal Control Officer shall post a notice at the animal owner's residence in a conspicuous place and take the animal to the City

animal shelter for impound. The Animal Control Officer shall make every reasonable attempt to minimize the animal's stay in the shelter to minimize costs to the owner and City. The animal owner must pay, or make legally binding arrangements to pay, all fines and costs of impound prior to retrieving the animal. The failure of an animal owner to reclaim their animal shall constitute abandonment.

4. The Animal Control Officer shall issue a letter to the animal owner documenting that the City provided at-large return service, and shall file a copy in the owner's registration records. This procedure is intended to reinforce the benefit and value of registration and shall NOT be used in a negative manner against an animal owner unless the animal owner is non-cooperative in mitigating such behavior or the behavior becomes habitual in excess of six times per calendar year.

F. The Animal Control Officer shall investigate each complaint of nuisance behavior by first issuing a notice letter to the animal owner, including a copy of the complaint and anticipated fines to be assessed, for the owner's written response. The owner's response shall provide a proposed remedy for the offending behavior. In the event the owner is uncooperative in mitigating and attempting to end the nuisance behavior, a citation shall be issued for resolution at the discretion of the court.

G. In responding to a complaint of nuisance behavior charges, the animal owner may mail a check to the City for the total assessed fines or optionally request a hearing before the City Court Judge or the Animal Control Advisory Board, should one exist, for arbitration.

H. If the violation involves sanitation on private property, public health inspectors may make periodic visits to assure sanitation is maintained.

I. Six nuisance violations in one calendar year shall automatically result in the animal being designated at-risk and subject the animal and owner to the various sanctions prescribed under the section heading "At-risk animals" in this code.

J. An animal owner shall be assessed an additional fine for nuisance behavior, that is NOT an at-large violation, when the animal is NOT registered with the City.

06. At-risk Animals.

- A. An at-risk animal designation shall be assigned to an animal that:
1. runs at-large, is NOT registered with the City, and has a current rabies vaccination;
 2. is NOT neutered and is NOT continuously confined on the owners property, either inside the residence of the owner or in a secure enclosure suitable to prevent escape of the animal or access to the animal by another at-large animal intent on breeding, but exempting female animals under the direct control of the owner, that are NOT in season and for which neutering is NOT a normally accepted practice for the species;
 3. runs at-large, is NOT registered with the City, and is not a mammal;
 4. runs at-large, is NOT registered with the City, and is a non-carnivorous mammal without a current licensed rabies vaccination and for which licensed vaccinations are listed and available according to the current NASPHV Compendium of Rabies Control and Prevention;
 5. runs at-large, is NOT registered with the City, is NOT a small rodent, and is a non-carnivorous mammal without a current licensed rabies vaccination because no licensed rabies vaccination exists;
 6. is NOT registered with the City and is NOT kept on a leash handheld by a legally responsible person when on public property or rights-of-way, because the animal owner is NOT a resident of the City;
 7. menaces, chases, displays threatening or aggressive behavior or otherwise threatens or endangers the safety of any adult person, who is otherwise NOT trespassing on the property of the owner, nor injuring or attempting to injure the animal itself, or the animal's owner or family members or property, but excluding any person (adult or child) in the commission of a crime;
 8. is permitted to cause unsanitary, odorous, or dangerous conditions potentially or actually affecting the health of the animal, the owner's family, or neighbors;
 9. accidentally causes physical injury to another domestic animal requiring veterinary services and resulting in necessary and reasonable treatment as determined by the veterinarian;
 10. aggressively snarls or otherwise threatens to bite when any person places an artificial hand near the animal's food or toys or other item in the animal's mouth;
 11. is injured, diseased, or sick and does NOT appear to be receiving appropriate veterinary care;
 12. suffers from cruelty, neglect, or abuse;
 13. lives in a filthy and unhealthy environment;
 14. does NOT appear to be receiving adequate care;
 15. has received more than six nuisances violations in one calendar year;
 16. was previously designated as an At-risk animal within the past 18 months:
- B. A decision chart is provided at Appendix Z to assist the Animal Control Officer in determining the appropriate escalating behavior to be assigned to an animal found running at-large.

C. In emergency situations, the Animal Control Officer may immediately seize the animal and place it with a veterinarian, foster care, or in the City animal shelter pending investigation and court adjudication of the complaint. Appropriate veterinary care must be provided by the City when indicated, to include humane euthanasia by the veterinarian, and shall be reimbursable to the City by the owner of the animal.

D. Sanctions for owning or harboring an at-risk animal: As the result of receiving a designation as an at-risk animal, the court may order and impose on the animal owner and at the owner's expense, any combination of the following requirements to protect the public interest and welfare of the animal as relevant and applicable to the particular violation(s):

1. City registration, including photographs of the animal.
2. Proof of \$100,000 to \$250,000 in liability insurance covering the animal's risk to the community, and requiring 10 day advance court notification of the intent to modify or cancel said insurance.
3. Probationary period of any appropriate duration, NOT to exceed 18 months.
4. Proof of immediate neutering of the animal by a licensed veterinarian.
5. Proof of compliance with any other veterinary care deemed necessary by the Animal Control Officer or licensed veterinarian.
6. Relinquishment of ownership of the animal for adoption or destruction.
7. Assessment of Fees and Fines in accordance with this code.
8. Proof of microchip implant for permanent identification of the animal.
9. Proof of construction of a secure enclosure to keep the animal confined on the owner's property, as inspected and approved by the Animal Control Officer.
10. Requirement to keep the animal on a leash of no more than four feet in length and under the control of a legally responsible person, when off the owner's property.
11. Requirement to muzzle the animal whenever the animal is off the premises of the owner.
12. Proof of satisfactory completion of private or group obedience class.
13. Evaluation by an animal behavior specialist with an associated recommendation involving the animal's probable outcome.
14. Proof of attendance and completion at responsible ownership class.
15. Requirement to pay all expenses of a victim of the animal, whether intentional or accidental.
16. Requirement to purchase and place a specific and identifying collar on the animal that would be immediately visible in the dark and light.
17. Community service hours credited at the Federal Minimum Wage Rate, due to a financial hardship resulting in an inability to pay Fees and Fines or other penalties assessed.
18. Any other sanction deemed appropriate by and at the discretion of a court of competent jurisdiction.

E. Sanctions shall be applied equitably, fairly, and consistently in every instance.

F. A summary of the complaint, designation, and each sanction applied to the case shall be published in a local newspaper by the Animal Control Officer.

4/30/2008

G. Failure to comply with any court ordered remedy imposed on the owner shall constitute contempt of court and shall result in immediate seizure of the animal for adoption, foster care, or destruction as deemed appropriate by the court; and the maximum fine permitted a City under State law; and one day in jail.

H. Satisfactory compliance with all court ordered sanctions shall cause the removal of the at-risk designation from the animal.

DRAFT

07. Dangerous Animals.

- A. A dangerous animal designation shall be assigned to an animal that:
1. displays symptoms of rabies;
 2. is a carnivorous (meat-eating) mammal that does NOT have a current licensed rabies vaccination;
 3. without justification or provocation attacks a person or another domestic animal causing death or serious physical injury requiring professional medical or veterinary services;
 4. menaces, chases, displays threatening or aggressive behavior or otherwise threatens or endangers the safety of any child, providing that the behavior of the animal was NOT the result of being teased, tormented, or provoked;
 5. is used in the commission of a crime, including but not limited to animal fighting, menacing, or guarding illegal operations;
 6. behaves in a manner that poses a real and unjustified imminent threat of serious injury or death to one or more persons who possess rational judgment;
 7. is an animal species prohibited within the City's jurisdiction;
 8. was previously designated a Dangerous Animal within the past 18 months.
- B. Any person may protect themselves, another person, or domestic animals from a dangerous animal in an emergency situation with appropriate force, including killing the animal, however, the Animal Control Officer and Sheriff's department must be summoned immediately. In any ensuing investigation, a person may be held liable for use of inappropriate force against an animal so killed should it be determined through investigation that the situation did NOT constitute an emergency and that ample time to obtain assistance from a law enforcement officer was available and prudent.
- C. A potentially dangerous animal shall be immediately impounded at the City animal shelter or alternate site by the Animal Control Officer or any law enforcement officer pending disposition of the case in a court of competent jurisdiction.
- D. It shall be a defense to a biting or attack charge when an animal is reacting to: pain from injury, inhumane treatment, trespass, provocation, threat of bodily harm to the owner or family, or other similar mitigating or extenuating circumstances.
- E. Mandatory humane euthanasia shall be imposed on an animal that:
1. without justification or provocation attacked its victim and such attack ultimately resulted in the death of the victim;
 2. displayed symptoms of rabies such that the probability of rabies infection is highly suspected as observed by a veterinarian or by two or more individuals responsible for protecting the public safety, again taking great care to preserve and keep intact the head and spinal column for testing;
 3. without justification or provocation attacked a child causing serious injury;
 4. without justification or provocation attacked an adult or another domestic animal causing facial disfigurement or serious loss of function in an appendage or other injury requiring significant hospitalization;

5. is a carnivorous mammal and NOT vaccinated for rabies because no licensed rabies vaccination is available for the animal and hence the animal is prohibited within the City's jurisdictional boundaries;
6. is an animal with a previous designation as a dangerous animal and is found running at-large or repeating dangerous animal behavior.

F. Mandatory sanctions required to be imposed on the animal owner by a court of competent jurisdiction after designating an animal as a dangerous animal when the animal owner declines to relinquish ownership of said animal for destruction are as follows:

1. Evaluation of the animal by an animal behavior specialist with an associated recommendation involving the animal's probable outcome;
2. Proof of a minimum of \$500,000 in liability insurance covering the animal's risk to the community, and requiring 10 day advance court notification of the intent to modify or cancel said insurance;
3. Proof of construction of a secure enclosure to keep the animal confined on the owner's property, as inspected and approved by the Animal Control Officer, with "Dangerous Animal" signs conspicuously posted on each side of the enclosure;
4. Requirement to keep the animal muzzled and on a leash of no more than four feet in length and under the control of a legally responsible person, when off the owner's property;
5. Requirement to pay all expenses of a victim of the animal;
6. Requirement to purchase and place a specific and identifying collar on the animal that would be immediately visible for 50 feet in the dark and light;
7. Probationary period of NOT less than 18 months;
8. Proof of microchip implant for permanent identification;
9. Assessment of fees and fines in accordance with this code.

G. The court may impose any additional sanctions deemed appropriate and applicable, in its sole discretion, to the particular violation.

H. A summary of the complaint, designation, and each sanction applied to the case shall be published in a local newspaper by the Animal Control Officer.

I. During transport, a dangerous animal shall be confined in a locked crate or locked vehicle and in a manner sufficient to prevent any person, especially children, from coming into contact with the animal through an opening.

J. Failure to comply with any court ordered remedy imposed on the owner shall constitute contempt of court and shall result in immediate seizure of the animal for destruction; and the maximum fine and jail sentence permitted a City under State law.

08. Wild Animals or Exotic Animals.

A. Wild or exotic carnivorous mammals and the hybrids of such animals are strictly and specifically prohibited in the City, because these animals cannot be vaccinated against rabies, and pose an inherent danger to the public safety as well as the domestic animal population.

B. Bats, coyotes, skunks, foxes, and raccoons are especially dangerous to humans and domestic animals because of the incidence of rabies in the populations of these animals. Muskrats have also become a rabies threat in the general area of this City. Great care should be taken to avoid contact with these animals.

C. According to numerous experts such as the ASPCA (American Society for the Prevention of Cruelty to Animals) and the AVMA (American Veterinary Medical Association), wild or exotic animals are NOT well suited to living with humans and domestic animals in a community setting because of their instinctive, regressive, and unpredictable behavior and substantial threat of disease. Such animals are generally discouraged within the City because of the constant and potential threat of escape into the community, and threat of potential harm to its human and domestic animal population.

D. Wild or exotic animals that may: excrete poison or venom; bite, claw, or slash so as to cause disfigurement of the victim or the loss of fingers, toes, or limbs or substantial blood loss; suffocate a victim by contraction; kill or severely injure a victim by trampling, stepping on, kicking, or impaling on horns; hit, slap, punch, throw, beat, brutalize, or overpower a victim so as to inflict serious injury or death are specifically prohibited within the City's jurisdictional boundaries.

E. The most comprehensive list of specific wild and exotic animals prohibited within a city has been developed by the City of New York and is included herein by reference, to wit: Health Code of the City of New York, Title 24 Department of Health, Title IV Environmental Sanitation, Article 161 Animals, 24 RCNY Health Code 161.01 (b) and (e).

F. It shall be unlawful to harbor any wild or exotic animal within the City without first completing City registration and obtaining a Wild/Exotic Animal Permit from the Animal Control Officer, including mandatory microchip implant of such animal, unless deemed inadvisable by a State licensed veterinarian in writing.

G. Any person who was in legal possession of a prohibited wild or exotic animal prior to the effective date of this code may continue to possess such animal by completing City registration and obtaining a Wild/Exotic Animal Permit.

H. Proof of liability insurance in the amount of one million dollars for each occurrence must be presented to the City at the time of registration. Said insurance shall NOT be cancelled or modified without immediately notifying the City and Animal Control Officer. Public schools are assumed to already possess adequate liability insurance to cover this risk.

I. Confinement and housing of any wild or exotic animal, including perimeter fencing surrounding interior pens and buildings, shall provide a safe and secure enclosure appropriate to the species.

J. Owners must immediately notify the authorities of the escape of a wild or exotic animal.

K. When wild or exotic animals are transported in this City, said animals shall be confined in a locked crate inside a closed, locked vehicle to prevent opportunities for escape and in a manner sufficient to prevent children from coming into contact with the animal through an opening in the vehicle.

L. It is unlawful to breed a wild or exotic animal within the jurisdictional boundaries of this City.

M. Any Animal Facility, including but not limited to a pet shop, shall not offer for sale, import, or breed any wild or exotic animal in this City.

N. A wild or exotic animal shall not be allowed off the premises of the owner or keeper except to visit a State licensed veterinarian. Wild or exotic animals may NOT be taken into publicly owned properties, such as parks and recreation areas, under any circumstances.

O. A Wild/Exotic Animal Permit shall contain additional information not already provided on the City registration, and shall include but not be limited to, City registration number and the name, address, and telephone number of owner for cross-reference; the animal's scientific name (class and order), breed, and/or common name; the name, address, and telephone number of the veterinarian who will provide care for the animal; a description, including supporting documentation, of the potential harm the animal may inflict including physical injury and disease which reflects the owner's cognizance of the risk; an acknowledgement that the applicant is of legal age and assumes liability for any costs associated with the animal incurred by the City or another individual; a sworn affidavit to authorize and permit any law enforcement officer, the Animal Control Officer, or other local government official on the premises where the animal is confined without warrant; a checkbox indicating proof of liability insurance provided at City registration and the insurance company name, telephone number, and point of contact of the insurer.

P. Public schools shall be required to complete a Wild/Exotic Animal Permit but the fees shall be waived by the City in the interest of education.

09. Feral Cat Plan.

- A. The most effective strategy currently available to reduce feral cat populations is the Trap-Neuter-Return (TNR) program, in which cats are spayed or neutered, vaccinated, ear-tipped or micro-chipped for identification, and then returned to the area from which they were trapped. TNR programs are the most effective solution for reducing feral cat populations and protecting the community.
- B. Feral cat colonies must be identified. If there are caregivers in the area they will be contacted, because many of these people may be willing to make a donation toward sterilization and vaccinations.
- C. The colonies will be trapped by the Animal Control Officer twice a year, preferably in February and then again in the fall.
- D. Cats that are old, sick, or injured will be removed from the colony for immediate veterinary care or humane euthanasia. A veterinarian will make these decisions.
- E. All cats over seven weeks old will be spayed, neutered, vaccinated, ear-tipped or micro-chipped for identification, and returned to the area where they were trapped.
- F. The veterinarian along with the Animal Control Officer will keep records of all cats that are trapped under this plan.
- G. In the areas feral cats are deemed to be nuisance animals and have no caregivers, the cats will be trapped and sent to farms, or to the veterinarian for humane euthanasia.

10. Cruelty, Abuse, Abandonment, and Neglect.

- A. An act of abuse, abandonment, neglect, or failure to provide adequate care are all forms of cruelty to animals and may be prosecuted either under State law* or this Animal Control Code as may result in the harshest penalties to the owner or other persons committing such acts.
- B. Any act of abandonment, abuse, neglect, cruelty, or failure to provide adequate care is unlawful in this City and shall result in the maximum municipal penalty permitted under State law*, with each day of such violation constituting a separate offense.
- C. The failure of a driver to provide immediate care and attention, including veterinarian care, to an animal struck by the driver's car constitutes cruelty to animals.
- D. When more than one animal is involved in acts of cruelty, abuse, abandonment, neglect, or failure to provide adequate care, each animal involved in such acts shall comprise a separate offense.
- E. Traditional domestic animal practices such as tail-docking, declawing, and ear cropping are exempt from charges of cruelty, abuse, or neglect when humanely performed by a licensed veterinarian.
- F. Inadvertent or intentional breeding of an individual animal to result in more than one pregnancy per year constitutes abuse, neglect, and cruelty.
- G. Animal husbandry and training methods using a broad spectrum of equipment and practices may be exempt from charges under this section when such practices are widely recommended, used, and accepted by a nationally recognized organization such as the American Veterinary Medical Association, American Kennel Club, Humane Society of the United States, United States Department of Agriculture, and the like.
- H. Pest animals such as mice, rats, gophers, and the like may be eliminated from the City's jurisdiction by whatever means necessary, and such removal is exempt from charges of cruelty.
- I. It is unlawful and constitutes neglect to release small, non-carnivorous mammals, including lagomorphs (rabbits and hares) and other small rodents such as: hamsters, guinea pigs, gerbils, and the like which were kept as domesticated animals for 4H projects or other similar endeavors.
- J. A person convicted under this section, shall be required to forfeit all animals in their possession to the City for adoption or other disposition.
- K. A person convicted under this section, shall be required to pay all reasonable costs incurred in providing necessary veterinary treatment and adequate care for any animal involved in such violation, including impound during adjudication of the case.

4/30/2008

L. Confining incompatible animals together constitutes cruelty.

M. Animal fighting will be prosecuted under State law* as a felony.

- * MCA 45-8-211. Cruelty to animals -- exceptions.
- 45-8-217. Aggravated animal cruelty.
- 45-8-210. Causing animals to fight--...

DRAFT

11. Confinement.

A. Adequate and appropriate animal confinement is a form of control and is the responsibility of the animal owner or other legally responsible person agreeing thereto.

B. A fence is an acceptable form of confinement when such fence is of sufficient height, strength, materials, and repair to safely contain an animal on the premises of the owner or other responsible person while preventing children from accessing the animal either by entering the animal's yard or enclosure or through the fence itself.

C. Fences to confine animals adjudicated and designated as at-risk or dangerous must qualify as a secure enclosure.

D. Underground fences are NOT recommended to contain animals out of the presence of an owner or other responsible person and should NOT be used as a primary method of confinement.

E. Animals shall NOT be tethered as a primary method of confinement if the animal constantly strains against the tether or displays aggressive behavior towards a passerby. Tethers may be used as a secondary form of restraint within a fenced area in order to prevent children from accessing an animal through a fence. Tethers may be used as a temporary form of restraint when the owner or other responsible person is also present on the premises. An animal shall NOT be forced to remain on a tether for more than 5 hours per day and only then during daylight hours, and when the animal also has access to shelter out of the elements and water and food.

F. Animals traveling in vehicles shall be confined inside the vehicle itself, crated, or cross-tied so as to prevent escape or accidental injury to the animal and to prevent children from placing fingers or hands in the animal's space.

G. Animals designated as at-risk or dangerous shall be confined inside a residence or other structure so as to prevent escape through screens or other such flimsy and penetrable barriers.

12. Animal Facilities.

- A. Endeavors which qualify as an Animal Facility are as stated in the definition.
- B. An Animal Facility shall first be in compliance with any City zoning regulations or other City ordinances, and thereafter must obtain a City permit as an Animal Facility prior to beginning operation.
- C. A breeding activity shall obtain a City permit prior to arrival of offspring. A hobby breeder shall be construed to be a breeding activity.
- D. A permit application shall be submitted to the Animal Control Officer together with a non-refundable fee to cover the City cost of facility inspection and application processing, to include veterinary consultation, as deemed necessary by the Animal Control Officer.
- E. The Animal Control Officer may, in his/her sole discretion, approve or disapprove or withdraw a permit for an Animal Facility.
- F. The Animal Control Officer shall develop specific criteria for inspecting the premises of a proposed Animal Facility. Such criteria shall NOT include volume discounts or a decrease in standards that would otherwise be imposed on any other animal owner or keeper. An experienced public health inspector, currently employed by another public agency, shall be consulted for assistance in developing such criteria.
- G. All provisions of this Animal Control Code shall apply in full to each and every animal kept in an Animal Facility.
- H. An Animal Facility shall be inspected at least once each calendar year without advance warning, and immediately in the advent of a complaint.
- I. An Animal Facility shall NOT continue operation without a valid City permit, and upon permit withdrawal the responsible person shall immediately cease operation of the Animal Facility.

13. Complaint Procedure.

- A. Any action involving Animal Control requires completion of the Animal Control Complaint Form in advance, unless the problem constitutes an emergency. In that event, the form shall be completed as soon as possible.
- B. Any person, including the Animal Control Officer, may complete an Animal Control Complaint Form.
- C. The Animal Control Complaint Form is located at Appendix A.
- D. The complaint procedure is as follows:
1. Obtain a blank form and turn in completed forms at City Hall or the Sheriff's Department.
 2. The Animal Control Officer will pick up the completed forms from City Hall or the Sheriff's Department within one working day*.
 3. The Animal Control Officer will set up a case file regarding the complaint. This file is to be kept for a period of five (5) years.
 4. The Animal Control Officer will notify, in writing, the animal owner of the charge. The notice will be mailed with return receipt request, or hand delivered, with the date and time the animal owner received the complaint recorded. Included will be a copy of the complaint and an opportunity for the animal owner to respond to the charge, also in writing, within two (2) days of receipt of the complaint.
 5. The Animal Control Officer will investigate the complaint within two (2) working days of the animal owner's response or his attempt to contact the owner.
 6. Results of the investigation may result in a citation, or a proposed remedy in the event of nuisance behavior. The Animal Control Officer will prepare a formal agreement to be signed by the animal owner. Failure to comply will result in the issuance of a citation.
 7. Citations shall be reviewed by the City Attorney and filed with the appropriate Court for disposition.
 8. The Court may permit the animal owner to submit to binding arbitration with the Animal Advisory Control Board, should one exists.

* Working days are the working days of the Animal Control Officer.

14. Fees and Fines.

- A. City registration fees for all mammals shall be tied directly to Rabies vaccination expiration and collected all at one time. If a Rabies vaccination expires in three years, so shall the City registration, and on the same date.
- B. The City Council may, in open session, waive fees in financial hardship cases. It is in the City's best interest to have an animal and owner in compliance with this code.
- C. The Court may authorize community service hours at the Federal Minimum Wage Rate in lieu of cash.
- D. Unless the context requires otherwise, fees and fines shall be as follows:

COSTS	DISCOUNTS	FEE or FINE
\$10 / year		Registration mammal
	(\$2.50) / year	Neutered
	(\$1.50) / year	All other species inoculations per Veterinarian list
	(\$1.00) / year	Microchip implant
	(\$2.00) / year	Senior Citizen (eligible for Social Security Benefits)
\$12		Registration non-mammal (lifetime)
At Cost		City Identification/Registration Tag for Collar
\$15 / day		Impound
Impound fee minus \$5		At-large return service
\$1 / day Up to \$100		Late penalty for unpaid at-large return service more than 3 days since violation
\$5 / occurrence up to \$20		City must issue bill to animal owner for unpaid at-large return service after 3 days
FREE		Nuisance Animal 1st Offense per calendar year
\$10 additional		Nuisance Animal each subsequent offense
\$30		Nuisance Animal NOT registered with City
\$40		Animal Facility Inspection (annually/via complaint)
\$50		Wild/Exotic Animal Permit (annually)
\$50		At-risk Animal administration
\$100		Dangerous Animal administration
\$500		Contempt of Court (failure to comply with orders)
Variable to \$500		Court ordered fines at judge's discretion

15. Animal Control Officer.

A. The Animal Control Officer is an employee of the City and falls under the direct supervision of the Mayor and City Council.

B. If hired without appropriate and sufficient training, the City shall provide and ensure that the Animal Control Officer acquires eighty hours of training within the first two years of employment, such as that provided by the National Animal Control Association, and at least one continuing education course each year thereafter.

C. The Animal Control Officer is at increased risk of contracting the rabies virus, much like a veterinarian, and should thereby consider pre-exposure treatment as advised by the public health officer or a medical expert.

D. It is unlawful for any person, other than the Animal Control Officer or other qualified government official, to set animal traps of any kind. Any individual may request the Animal Control Officer to set a trap on their own private property, but said individual shall NOT touch the trap or any animal contained therein, except to prevent injury to the animal in an emergency situation, while being cognizant of his/her own potential health or safety risk to do so. A private property owner shall notify the Animal Control Officer immediately when an animal is caught in a trap placed on their private property at the owner's request.

E. The duties of the Animal Control Officer are those specified in the City's Employee Handbook or Personnel Policy and this Animal Control Code and should a conflict arise, the duties and powers contained in this Animal Control Code shall control and supersede.

F. It shall be unlawful for any person to interfere with the Animal Control Officer's exercise of duties assigned in this code.

G. It shall be unlawful for any person to act on his/her own volition rather than contacting the Animal Control Officer to perform duties assigned herein.

H. The Animal Control Officer shall:

1. NOT perform euthanasia unless professionally certified by the State to do so and then only under the direct supervision of a licensed veterinarian, and only then utilizing the most highly recognized and humane method acceptable to the professional veterinary community for the particular situation; (Great care shall be taken to keep whole and preserve the head and spinal cord area of any animal suspected of rabies infection for testing and also to avoid exposing and spreading the rabies virus by splattering neural tissue onto mucous membranes or wounds of other mammals.)
2. NOT administer any substance to an animal by injection.
3. immediately contact the public health officer and local veterinarian for guidance and consultation, whenever an animal bite occurs within the City's jurisdiction;

4. request and is authorized to receive the assistance of law enforcement officers from the Sheriff's department (aka City-County Consolidated Department of Public Safety), whenever deemed prudent;
5. thoroughly investigate and document a complaint;
6. enforce and administer all provisions of this Animal Control Code currently in effect;
7. humanely provide adequate care to any animal seized, taken into custody, and impounded as necessitated by the exercise of the powers and duties within the Animal Control Code;
8. keep and maintain complete and accurate records of all actions taken in the course of performing the powers and duties contained in this code, and produce all such records for public viewing at reasonable hours and times wherever said records may be located. These records should NOT include private indentifying information, but may include information already available in the public domain such as the phone book or property records. The public shall be permitted to take notes, request a copy, or use other privately owned electronic media storage devises to make copies of said records on the premises. Standard fees will be charged for copies provided by the officer;
9. ensure timely and sufficient (minimum of seven weekdays) notification to an owner in the event an animal is impounded by a) telephone, b) hand delivery receipt, c) posting at the last known address, or d) finally by certified-return-receipt mail. Whenever direct contact with the owner cannot be achieved, the Animal Control Officer shall then place publication in the local newspaper on two separate occasions, to include the animal's picture, and an announcement on the local radio station. Such notification shall precede disposition of an animal prior to adoption or euthanasia, except in the case of probable rabies infection or extreme suffering of the animal, as determined by a licensed veterinarian;
10. obtain a warrant from a court of competent jurisdiction to enter upon the private property of an animal owner when said owner declines to voluntarily permit access, except when circumstances constitute an untenable emergency situation that will most likely result in additional serious harm or death without immediate action;
11. request and serve warrants as appropriate;
12. file complaints received with the appropriate authority;
13. be empowered to write citations as a consequence of complaint investigation and appear to testify in support of findings relevant to said complaints and citations;
14. maintain a professional and courteous demeanor;
15. judicially utilize the City animal shelter as a last resort, after exhausting other possible confinement scenarios such as at-large return service, foster care, veterinary care, etc. to minimize City costs and trauma to the animal, especially when subject animal is a victim of abuse, cruelty, neglect or the animal appears healthy (including evidence of current rabies vaccination) and seems to be lost or abandoned and is generally friendly;
16. maintain the City animal shelter in a overall sanitary condition, and ensure that necessary building maintenance is accomplished in a manner so as NOT to adversely affect any animal in custody;
17. ensure proper sanitization of any enclosure used to transport or house an animal before placing another animal in the same enclosure, taking extra care to eliminate

any saliva, or other remnants which may cause the spread of a communicable disease; (The local veterinarian shall be consulted to ensure appropriate cleaning materials are used.)

18. post, in an obvious place, the hours and days of the week or dates of operation outside the City animal shelter door, and also post an emergency or alternate phone number to be contacted in off hours;
19. respond as soon as possible to telephone messages and emails;
20. utilize humane traps;
21. obtain a written complaint for any action taken;
22. conduct at least one clinic each year at which vaccinations, registration, microchip implants, or neutering may be offered at a price that encourages pet owners to bring their pets and affords an opportunity for public education of responsible pet animal care;
23. remove, by whatever means necessary, an animal from a vehicle in either hot or cold weather when, in the best judgment of the officer, the animal's health and well being is endangered by such confinement;
24. develop an application procedure and specific criteria for inspecting the premises of a proposed Animal Facility and approve, disapprove, issue, or withdraw City permits for the operation of such facilities;
25. develop a Wild/Exotic Animal Permit form per the criteria set forth in the appropriate section of this code and approve, disapprove, issue, or withdraw City permits for the possession of such animals.

DRAFT

16. General Provisions and Administration.

- A. This Animal Control Code applies to the jurisdictional boundaries of the City of Shelby, Montana and is herein referenced as the "City".
- B. References to the word "State" throughout this Animal Control Code shall mean the State of Montana, except where the context requires otherwise.
- C. Oversight enforcement of this Animal Control Code is at the prerogative of the City's Mayor together with the City Council, in consultation with the City Attorney.
- D. Direct enforcement of this Animal Control Code is the responsibility of the Animal Control Officer, in consultation with the City Attorney.
- E. Judicial or disciplinary enforcement of this code is at the discretion of the City Court Judge and/or the Animal Control Advisory Board should one exist, and potentially the County Attorney and District Court with respect to State law violations, appeals, and violations exceeding dollar value thresholds.
- F. After initial adoption, this Animal Control Code shall be amended in part or whole by referendum or initiative submitted to the electors of this City.
- G. Violation of any item of this Animal Control Code shall constitute a misdemeanor offense, unless otherwise indicated, with each violation constituting a separate offense.
- H. The City shall provide a facility, equipment, supplies, training, and other tools adequate for the Animal Control Officer to appropriately house impounded animals and to effectively perform his/her other duties. The facility shall be called the City Animal Shelter and may be City owned, leased, or provided by contract with a private corporation.
- I. The City shall publish, in 12-point Arial font, this Animal Control Code in its entirety on the City's website, thus making the code widely available to the general population. Said file shall be presented in PDF format to maximize accessibility. The City shall make a hard copy of this code available at City Hall for reading and copying and may charge standard fees per page for copies, as applicable.
- J. The City may designate multiple sites as a licensing authority for animal registration as may be expedient and cost effective for the City as long as a centralized, real-time database of City registrations is maintained and accommodated through advancements in technology embraced by the City. The City shall consider using its website for renewal registrations utilizing credit card payments and providing for mail-in, email, or other paperless submission of the rabies vaccination documentation (NASPHV form 51) from a State veterinarian. Initial registrations shall be accomplished in person.
- K. An Animal Control Advisory Board may be appointed by the Mayor of the City to help defray litigation costs associated with enforcement of this code. Said board would consist

of seven volunteer members, with staggered appointment terms for continuity purposes. Said board should include broad representation across the community population, all of whom must own a registered animal and also one professional veterinarian if possible. The chair person of the board would be annually elected by the board members themselves. The purposes of the board shall be to hear and arbitrate minor disputes or appeals involving animals, review and recommend changes to the Animal Control Code, and otherwise broadly assist the Animal Control Officer and local government as requested. The board should have the authority of a magistrate appointed to hear and arbitrate minor disputes or appeals involving animal nuisances or minor neighborhood disputes involving animals, to impose penalties, to compel confiscation of animals, to cause inspection and remediation of premises, to assign animal owners to dog training or responsible ownership classes, to refer a case to City Court for adjudication, and the like. The Animal Control Officer may use the board to offer a violator of this Code an option of submitting to binding arbitration before the board in lieu of appearance in City court. The City court may also use this board to provide the option for a defendant to submit to binding arbitration. Decisions of the board, other than binding arbitration, may be appealed to City Court.

L. Severability. If any section, sentence, clause or phrase of this Animal Control Code is for any reason held to be invalid or unconstitutional by a decision of any court of competent jurisdiction such decision shall not affect the validity of the remaining portions of this code.

M. Conflict of Laws. State Law shall control and govern over this code except in instances where the subject is not addressed by State Law, where the subject is addressed by State Law but not addressed by this code, or State Law specifies standards or requirements in direct conflict with this code. This Animal Control Code shall control and govern when State Law is more lenient than this code regarding the same or similar provisions.

N. Appendices may be modified as helpful without changing the original intent and meaning, such as the requirement to obtain a signature to cause the effect of an affidavit, but the references to an appendix within the body of this code shall require amendment of the section so affected.

4/30/2008

ANIMAL CONTROL COMPLAINT FORM

Today's date: ___/___/___ Time: ___:___ AM / PM

Complainant's Information:

Printed Name: _____

Address: _____

Phone Number: _____

Signature: _____

(must be signed to be valid)

Description of complaint (who, what, when, where, why). Please include date, time, location, animal description, etc. and attach additional page if more room is required:

Animal Owner Information:

Animal Owner's Name (if known): _____

Address of owner: _____

Would you like the Animal Control Officer to contact you about this complaint?

____ Yes ____ No

Type of complaint: (to be determined by Animal Control Officer)

_____ Nuisance behavior

_____ At-risk behavior

_____ Dangerous behavior

In order to investigate complaints, adequate information must be provided to verify the complaint location and the alleged violation. Violations that can be verified by Animal Control may result in a citation or other measures may be taken to insure compliance with City code. Your assistance with this will be appreciated.

(For Animal Control Officer Use Only:)

Date Received:

Date notice sent/given to animal owner:

Time Received:

Investigation Contacts:

Initials:

Disposition:

Appendix A

2007 MCA (Montana Code Annotated) References used in the development of this code... (not all-inclusive).

07-1-4127.	Publication of notice – content – proof.
07-5-4104.	Control of nuisances – exception.
07-5-4202.	Incorporation of technical codes by reference.
07-5-4207.	Penalties for violation of municipal ordinance.
07-23-101 thru 105.	Local Government Control of Dogs.
07-23-2108 thru 2110.	County Control of Dogs.
07-23-4101 thru 4103.	Municipal Control and Protection of Domestic Animals.
07-23-4201 thru 4203.	Required Spaying or Neutering of Cat or Dog.
27-1-222.	Exemplary damages for inhumane injuries to animals.
27-1-715.	Liability of owner of vicious dog.
27-30-101.	Definition of nuisance.
27-30-102.	Distinction between public and private nuisances.
27-30-103.	Action for nuisance.
27-30-302.	Abatement of private nuisance by injured party.
37-18-102.	Veterinary medicine defined.
37-18-6xx.	Euthanasia Techniques and Agencies – Certification.
45-8-111.	Public nuisance.
45-8-112.	Action to abate a public nuisance.
45-8-210.	Causing animals to fight.
45-8-211.	Cruelty to animals-exceptions.
45-8-217.	Aggravated animal cruelty.
50-23-101 thru 106.	Rabies Control.
70-5-101 thru 107.	Rights and Duties of Finders Generally.
81-7-401 thru 403.	Livestock, Predatory Animal Control, Dogs.
87-3-124.	Dogs -- restrictions on hunting -- penalty for chasing hoofed game animals.

START HERE
An animal is AT-LARGE and

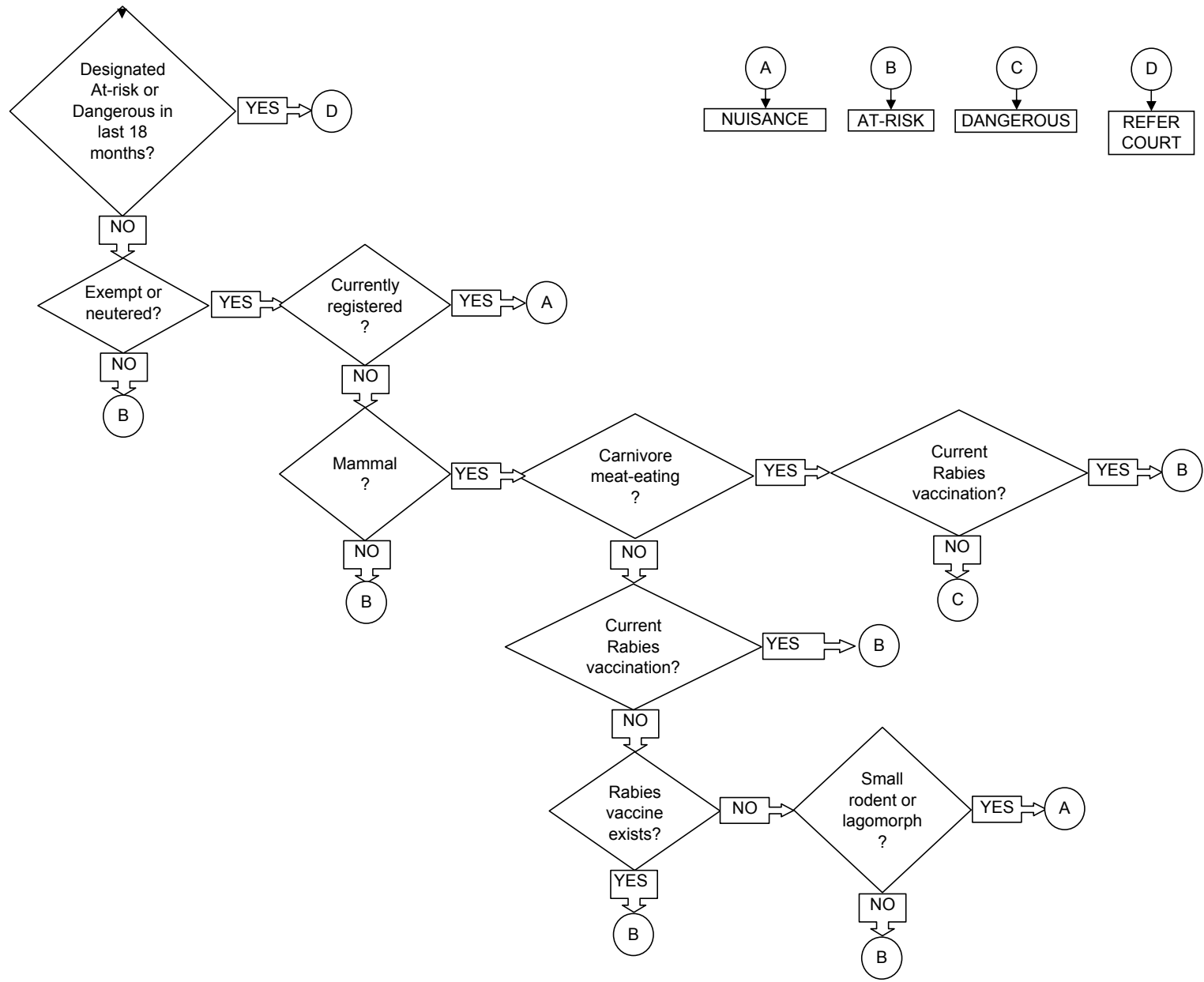

RUNNING AT-LARGE
Decision Chart
(see notes below)



Use this flowchart to determine and assign the correct Escalating Behavior represented by: A, B, C, D.

Note 1: A registered animal is presumed to be vaccinated for Rabies if it is a MAMMAL.
Note 2: A species prohibited in the City is a Dangerous Animal.